



Ranger® Count 1000

Counting Scales



Reliability, Portability and Accurate Counting Operations in One Affordable Package!

Ranger Count 1000 Counting Scales are designed to provide accurate counting results for basic operation in annual inventories, parts rooms, rental and other counting applications. With an internal counting resolution of 1:300,000, Ranger Count 1000 offers accuracy, durability and portability in one practical and surprisingly affordable design.

Standard Features Include:

- **Dedicated Counting Keypad Provides Fast and Simple Operation** — Ranger Count 1000's dedicated counting keypad includes numeric, Tare and Sample keys, makes counting operations simple and straightforward.
- **Average Piece Weight (APW) Memory Speeds Up Counting of Commonly Counted Parts** — The APW memory provides storage for up to 10 commonly-used part weights, speeding up counting operations and minimizing redundant work.
- **Continual Recalculation of Piece Weight Ensures Counting Accuracy** — Auto-optimization software recalculates the average piece weight with each batch of parts to ensure the accuracy of your parts counting process.

Ranger® Count 1000 Counting Scales

Model	RC11P3	RC11P6	RC11P15	RC11P30
Default Capacity × Readability	3000 g × 0.2 g 3kg × 0,0002kg	6000 g × 0.5 g 6kg × 0,0005kg	15000 g × 1 g 15kg × 0,001kg	30000 g × 2 g 30kg × 0,002kg
Displayed Resolution	1:15,000	1:15,000	1:15,000	1:15,000
Minimum Recommended Sample Weight	2 g	5 g	10 g	20 g
Minimum Recommended APW	0.02 g	0.05 g	0.1 g	0.2 g
Internal Counting Resolution	1:300000			
Construction	Plastic pan with Stainless steel inset, ABS plastic housing			
Weighing Units	g or lb (menu selected)			
Application Modes	Weighing, Counting, Accumulation			
Display	3-Window, backlit LCD 0.75in / 19mm High, 6-digit, 7-segment			
Memory	10 locations for APW			
Keypad	7 function, 11 numeric membrane keys			
Zero Range	4% of full scale capacity			
Tare Range	Full capacity by subtraction			
Stabilization Time	≤ 2 seconds			
Safe Overload Capacity	150% of capacity			
Power	AC Adapter 12V DC / 1000mA Internal rechargeable sealed lead acid battery			
Battery Life	80 hours continuous use with 12 hour recharge time			
Calibration	External with kg/g mass, factory calibration recovery			
Operating Temperature Range	0° to 40°C			
Pan Size (W × L)	294 × 226 mm			
Scale Dimensions (W × L × H)	325 × 330.5 × 114 mm			
Shipping Dimensions (W × L × H)	440 × 360 × 160 mm			
Net Weight	4.2 kg			
Shipping Weight	5.3 kg			

Approvals

• Electrical/Emissions: Meets requirements of approval agencies: UL (adapter), FCC, CE Safety EN61558, EMC EN61326

Accessory

SST Pan, RC11,A31..... 80120009

In Use Cover, RC11..... 80120028

Outline Dimensional Drawings

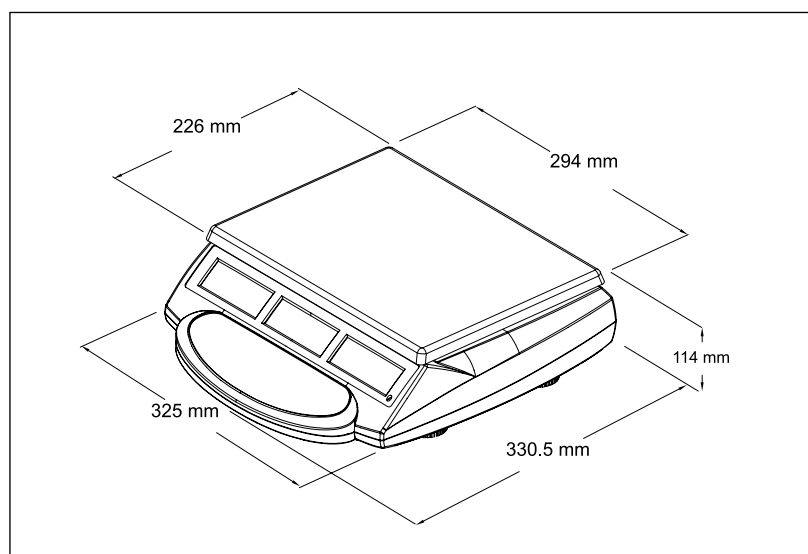

OHAUS Europe GmbH

Im Langacher 44
8606 Greifensee
Switzerland

e-mail: ssc@ohaus.com
Tel: 0041 22 567 53 19
e-mail: tsc@ohaus.com
Tel: 0041 22 567 53 20

www.ohaus.com

OHAUS Corporation is an
ISO 9001:2008 manufacturer

ISO 9001:2008

Registered Quality
Management System

