

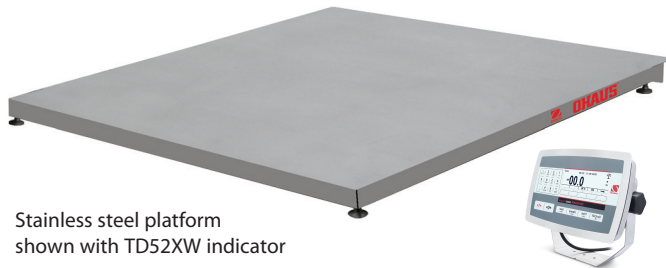

VE Plus Serie

Floor Platforms and Scales



Stainless steel platform
shown with TD52XW indicator



Mild steel platform and ramp shown with
TD52P indicator

Affordability, Durability, OHAUS Quality & Value

The OHAUS VE Plus Series floor platforms and scales are the value solution for your dry or washdown weighing needs in industrial and commercial applications. Their high-quality material and construction are designed to minimize distortion under heavy loads, and ensure years of dependable performance. Available also with corresponding ramps and mounting accessories, the OHAUS VE Plus Series floor platforms and scales offers a unique combination of value, quality and dependability that your company can rely on.

Standard Features Include:

- 1,500kg and 3,000kg capacities in three platform sizes: 1m x 1m, 1.25m x 1.25m, 1.5m x 1.5m
- Two platform versions with structural bracing that ensures a stiff and solid construction.
- Two rugged OHAUS indicator models:
 - TD52P indicator features a high-impact ABS housing with key-holes on the rear cover for wall mounting
 - TD52XW indicator features a 304 stainless steel IP68 stainless steel housing
- Four x OIML R60 approved IP67 alloy steel load cells
- Four x load cell mounted feet, self-swiveling ball-in-cup design
- Side access IP65 dust and water immersion protected stainless steel junction box with 5m long cable
- Includes two carbon steel eye bolts that allow easier lifting and positioning of the platform
- Available painted steel and stainless ramps with bottom support ribs that resist bending under heavy loads
- Available second stage verified scale models 1:3000e with OHAUS indicators and fixed-location mounting plates
- OHAUS indicators featuring backlit LCD displays with high-visibility 25mm high digits, multiple weighing units (kg, g, lb, oz, lb:oz, t), optional rechargeable Li-ion battery operation and piece counting function

VE Plus Serie Floor Platforms and Scales

Platform Models	VE1500S	VE1500R	VE3000R	VE1500L	VE3000L
Platform Material	Painted carbon steel, raised treaded surface, fixed top plate 5mm thick				
Net Weight	83kg	123kg		170kg	
Platform Models	VE1500SW	VE1500RW	VE3000RW	VE1500LW	VE3000LW
Platform Material	Stainless steel, sand-blasted flat surface, fixed top plate 5mm thick				
Net Weight	68kg	101kg		134kg	
Platform Size (A x B x min H)	1m x 1m x 9cm	1.25m x 1.25m x 9cm		1.5m x 1.5m x 9cm	
Capacity x Readability	1500kg x 0.5kg	1500kg x 0.5kg	3000kg x 1kg	1500kg x 0.5kg	3000kg x 1kg
Approval Resolution	1:3000e				
Operating Temperature / Humidity	-10°C to 40°C / 0% to 95% relative humidity, non-condensing				
Maximum Central Load	125% of rated capacity				
Load Cell	4 x IP67 alloy steel, shear beam, OIML C3, 5m cable length				
Load Cell Capacity Emax	1000kg	1000kg	1500kg	1000kg	1500kg
Output Impedance / Excitation Voltage	350 ohm ± 3.5 ohm / 5V~15V, DC/AC				
Feet	4 x self-swiveling ball-in-cup design with rubber bottom, adjustable height				
Junction Box	Side access, IP65, 304 stainless steel, with 5m long cable				
Scale Models (painted, with T31P indicator)*	VE1500S52P	VE1500R52P	VE3000R52P	VE1500L52P	VE3000L52P
Scale Models (stainless, with T32XW indicator)*	VE1500S52XW	VE1500R52XW	VE3000R52XW	VE1500L52XW	VE3000L52XW
Indicators	TD52P: ABS plastic, powder-coated steel bracket		TD52XW: 304 stainless steel with sand blasted surface treatment, stainless steel bracket		
Weighing Units	Kilogram, Gram, Pound: Ounce, Tonne (Metric Tonne), Ton (Short Ton), Custom unit				
Display	Dot matrix LCD with white LED backlight, 256 x 80 pixels				
Interface	Standard RS232, Micro SD Card (included) Optional Ethernet, WiFi/Bluetooth, 2nd RS232/RS485/USB, Analog Output, 2 In/4 Out Digital I/O				
Power	100-240 VAC / 50/60 Hz Universal Power Supply, Hardwired (TD52XW) or Line Cord (TD52P) Rechargeable Lithium Battery (optional)				
Battery Life	20 hours of continuous use				
Other Features	Basic Weighing, Percent Weighing, Piece Counting with Optimized APW, Checkweighing/ Checkcounting Dynamic Weighing/Display Hold				

*For 2nd stage EC Type approved Class III models, add "M" at end of scale model name (ex., VE1500S31PM) (will require available foot plate kits in type approved installations)

*Outline Dimensions (Platform Size)

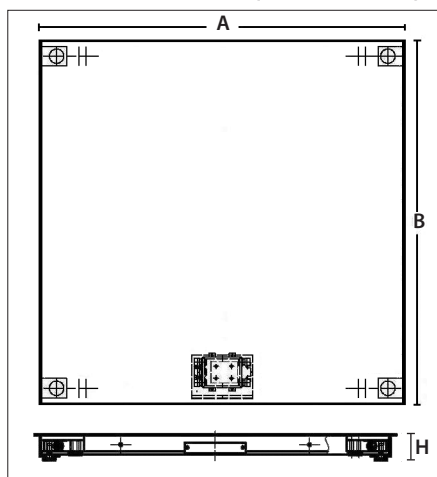

Options and Accessories

Wall mount bracket kit, T31P	80251747
Wall mount bracket kit, T32XW	80251748
Ramp kit, VE painted steel, 1m	72198338
Ramp kit, VE painted steel, 1.25m	72198339
Ramp kit, VE painted steel, 1.5m	72198340
Ramp kit, VE-W stainless steel, 1m	72198341
Ramp kit, VE-W stainless steel, 1.25m	72198342
Ramp kit, VE-W stainless steel, 1.5m	72198343
Foot plate kit, VE painted steel	72198344
Foot plate kit, VE-W stainless steel	72198345

Structural Features

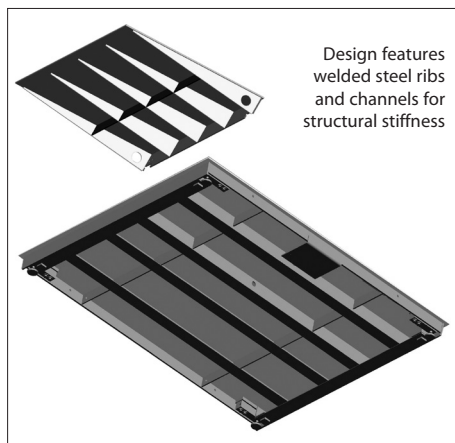

Accessories (Painted Steel & Stainless Steel)

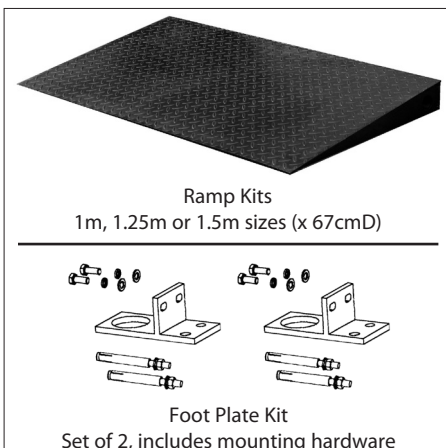

OHAUS Europe GmbH
Im Langacher 44
8606 Greifensee
Switzerland

e-mail: ssc@ohaus.com
Tel: 0041 22 567 53 19
e-mail: tsc@ohaus.com
Tel: 0041 22 567 53 20

www.ohaus.com

OHAUS Corporation is an ISO 9001:2008 manufacturer

ISO 9001:2008
Registered Quality
Management System

